



Dispense with Patient Information available at: <https://www.sunpharma.com/usa/products>

PATIENT INFORMATION

Tobramycin (toh-bruh-mahy-sin) Inhalation Solution, USP for oral inhalation use

What is tobramycin inhalation solution?

Tobramycin inhalation solution is a prescription medicine that is used to treat people with cystic fibrosis who have a bacterial infection called *Pseudomonas aeruginosa*. Tobramycin inhalation solution contains an antibacterial medicine called tobramycin (an aminoglycoside).

It is not known if tobramycin inhalation solution is safe and effective:

- in children under 6 years of age
- in people who have an FEV₁ less than 25% or greater than 75% predicted
- in people who are colonized with a bacterium called *Burkholderia cepacia*

Do not take tobramycin inhalation solution if you are allergic to tobramycin, any of the ingredients in tobramycin inhalation solution, or to any other aminoglycoside antibacterial.

See the end of this Patient Information for a complete list of ingredients in tobramycin inhalation solution.

Before you take tobramycin inhalation solution, tell your healthcare provider about all of your medical conditions, including if you:

- have or have had hearing problems (including noises in your ears such as ringing or hissing), hearing loss, or your mother has had hearing problems after taking an aminoglycoside.
- have been told you have certain gene variants (a change in the gene) related to hearing abnormalities inherited from your mother.
- have dizziness
- have or have had kidney problems
- have or have had problems with muscle weakness such as myasthenia gravis or Parkinson's disease
- have or have had breathing problems such as wheezing, coughing, or chest tightness
- are pregnant or plan to become pregnant. Tobramycin inhalation solution is in a class of drugs that can harm your unborn baby.
- are breastfeeding or plan to breastfeed. It is not known if tobramycin inhalation solution passes into your breast milk.
- are receiving aminoglycoside therapy by injection or through a vein (intravenous) while taking tobramycin inhalation solution. Your blood levels of tobramycin will be checked.

Tell your healthcare provider about all the medicines you take, including prescription medicines, over-the-counter medicines, vitamins, and herbal supplements.

How should I take tobramycin inhalation solution?

- **See the step-by-step Instructions for Use** about the right way to take your tobramycin inhalation solution.
- Take tobramycin inhalation solution exactly as your healthcare provider tells you. **Do not** change your dose or stop taking tobramycin inhalation solution unless your healthcare provider tells you to.
- The usual dose for adults and children over 6 years of age is:
 - o 1 single-dose ampule of tobramycin inhalation solution inhaled 2 times each day using a hand-held PARI LC PLUS™* Reusable Nebulizer and a DeVilbiss®* Pulmo-Aide®* air compressor.
- Each dose of tobramycin inhalation solution should be taken as close to 12 hours apart as possible.
- You should not take your dose less than 6 hours apart.
- Tobramycin inhalation solution is taken as a breathing treatment (inhalation) with a hand-held PARI LC PLUS* Reusable Nebulizer with a DeVilbiss* Pulmo-Aide* compressor. **Do not** use any other nebulizer for your tobramycin inhalation solution treatment.
- Do not mix or dilute tobramycin inhalation solution with dornase alfa or other medicines in your nebulizer system.
- Each treatment should take about 15 minutes.
- Tobramycin inhalation solution should be inhaled while you are sitting or standing upright and breathing normally through the mouthpiece of the nebulizer. Nose clips may help you to breathe through your mouth.
- If you forget to take tobramycin inhalation solution and there are at least 6 hours to your next dose, take your dose as soon as you can. Otherwise, wait for your next dose. Do not double the dose to make up for the missed dose.
- After using tobramycin inhalation solution for 28 days, you should stop using it and wait 28 days. After you have stopped using tobramycin inhalation solution for 28 days, you should start using tobramycin inhalation solution again for 28 days. Complete the full 28-day course even if you are feeling better. It is important that you keep to the 28-day on, 28-day off cycle.

If you are taking several medicines or treatments to treat your cystic fibrosis, you should take your medicines or other treatments before inhaling tobramycin inhalation solution or as directed by your healthcare provider. Tell your healthcare provider about all the medicines you take, including prescription and over-the-counter prescription medicines, vitamins, and herbal supplements.

Using tobramycin inhalation solution with certain other medicines can cause serious side effects.

If you are using tobramycin inhalation solution, you should discuss with your healthcare provider if you should take:

- other medicines that may harm your nervous system, kidneys, or hearing
- “water pills” (diuretics) such as ethacrynic acid, furosemide, or intravenous mannitol
- urea

Ask your healthcare provider or pharmacist for a list of these medicines, if you are not sure.

Know the medicines you take. Keep a list of them and show it to your healthcare provider and pharmacist when you get a new medicine.

What are the possible side effects of tobramycin inhalation solution?

Tobramycin inhalation solution may cause serious side effects, including:

- severe breathing problems (bronchospasm). Tell your healthcare provider right away if you get any of these symptoms of bronchospasm with using tobramycin inhalation solution:
 - o shortness of breath with wheezing
 - o coughing and chest tightness

- hearing loss or ringing in the ears (ototoxicity). Tell your healthcare provider right away if you have hearing loss or you hear noises in your ears such as ringing or hissing. Tell your healthcare provider if you develop vertigo, difficulty with balance or dizziness.
- worsening kidney problems (nephrotoxicity). Tobramycin inhalation solution is in a class of drugs which may cause worsening kidney problems, especially in people with known or suspected kidney problems. Your healthcare provider may do a blood test to check how your kidneys are working while you are using tobramycin inhalation solution.
- worsening muscle weakness (neuromuscular disorder). Tobramycin inhalation solution is in a class of drugs which can cause muscle weakness to get worse in people who already have problems with muscle weakness (myasthenia gravis or Parkinson's disease).

The most common side effects of tobramycin inhalation solution include:

- o increased cough
- o sore throat
- o increased sputum
- o coughing up blood
- o decreased lung function
- o trouble breathing
- o voice changes
- o loss or change in taste
- o rash

These are not all of the possible side effects of tobramycin inhalation solution.

Call your doctor for medical advice about side effects. You may report side effects to FDA at 1-800-FDA-1088.

General information about the safe and effective use of tobramycin inhalation solution

Medicines are sometimes prescribed for purposes other than those listed in a Patient Information leaflet. Do not use tobramycin inhalation solution for a condition for which it was not prescribed. Do not give it to other people, even if they have the same symptoms you have. It may harm them. You can ask your pharmacist or healthcare provider for more information about tobramycin inhalation solution that is written for health professionals.

What are the ingredients in tobramycin inhalation solution?

Active ingredient: tobramycin USP

Inactive ingredients: sodium chloride in water for injection, sulfuric acid, sodium hydroxide, and nitrogen

What is Pseudomonas aeruginosa?

It is a very common bacterium that infects the lungs of nearly everyone with cystic fibrosis at some time during their lives. Some people do not get this infection until later in their lives, while others get it very young. It is one of the most damaging bacteria for people with cystic fibrosis. If the infection is not properly managed, it will continue to damage your lungs causing further problems to your breathing.

For more information, call 1-800-818-4555.

Distributed by:
Sun Pharmaceutical Industries, Inc.
Cranbury, NJ 08512

Manufactured by:
Sun Pharmaceutical Medicare Limited
Baska Ujjeti Road, Ujjeti
Halol-389350, Gujarat, India

This Patient Information has been approved by the U.S. Food and Drug Administration.

Instructions for Use

Tobramycin (toh-bruh-mahy-sin) Inhalation Solution, USP for oral inhalation use

Read this Instructions for Use before you start using tobramycin inhalation solution and each time you get a refill. There may be new information. This leaflet does not take the place of talking to your healthcare provider about your medical condition or treatment.

Tobramycin inhalation solution is made for inhalation using a PARI LC PLUS™* Reusable Nebulizer and a DeVilbiss®* Pulmo-Aide®* air compressor. Tobramycin inhalation solution can be taken at home, school, or at work. The following instructions tell you how to use the DeVilbiss®* Pulmo-Aide®* air compressor and PARI LC PLUS* Reusable Nebulizer to administer tobramycin inhalation solution.

You will need the following supplies (See Figure A):

- 1 tobramycin inhalation solution plastic ampule (tobramycin inhalation solution is packaged with 4 ampules in each foil pouch)
- DeVilbiss®* Pulmo-Aide®* air compressor
- PARI LC PLUS* Reusable Nebulizer
- Tubing to connect the nebulizer and compressor
- Clean paper or cloth towels
- Nose clips (optional)

Figure A

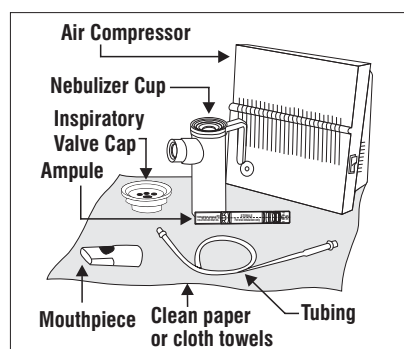

It is important that your nebulizer and compressor function properly before starting your tobramycin inhalation solution therapy.

Note: Read the manufacturer care and use instructions for important information.

Prepare Your Tobramycin Inhalation Solution for Inhalation Therapy

Step 1: Wash your hands thoroughly with soap and water.

Step 2: Open the foil pouch.

Step 3: Separate 1 tobramycin inhalation solution ampule by gently pulling apart at the bottom tabs (See Figure B). Place the remaining tobramycin inhalation solution ampules in the refrigerator.

Figure B



Step 4: Check the expiration date stamped on the tobramycin inhalation solution ampule (See Figure C). **Do not** use the tobramycin inhalation solution ampule if the expiration date has passed.

Figure C

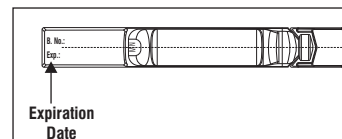

Step 5: Check that the tobramycin inhalation solution ampule medicine is clear and does not have particles.

- Unrefrigerated tobramycin inhalation solution, which is normally colorless to light yellow, may darken with age. This color change does not mean there is any change in the quality of the medicine.
- **Do not** use the tobramycin inhalation solution ampule if the medicine is cloudy or has particles.
- Throw it away and get a new one.

Step 6: Lay out the parts of a PARI LC PLUS* Reusable Nebulizer package on a clean, dry paper or cloth towel. You should have the following parts (See Figure D):

- Nebulizer Top and Bottom (Nebulizer Cup) Assembly
- Inspiratory Valve Cap
- Mouthpiece with Valve
- Tubing

Figure D

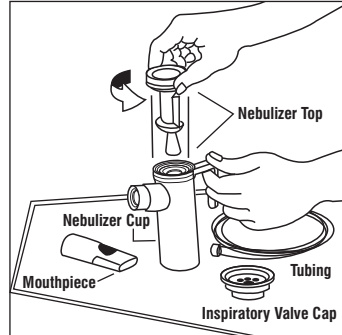

Step 7: Remove the Nebulizer Top from the Nebulizer Cup by twisting the Nebulizer Top counter-clockwise, and then lifting off (See Figure E).

Figure E

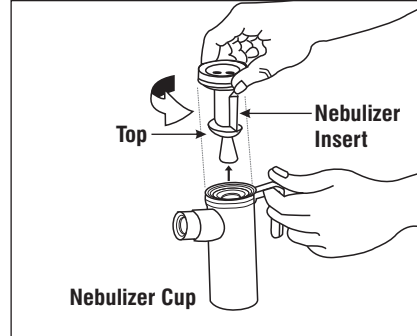

Step 8: Place the Nebulizer Top on the clean paper or cloth towel by standing the Nebulizer Cup upright on the towel (See Figure F).

Figure F

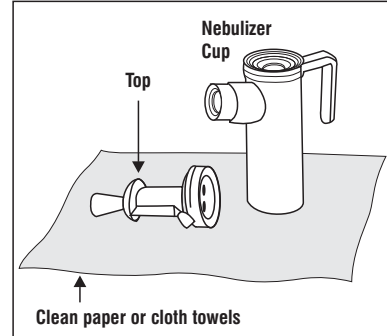

Step 9: Connect one end of the tubing to the compressor air outlet (See Figure G). The tubing should fit tightly.

Figure G

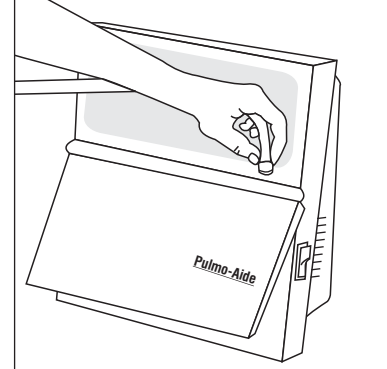

Step 10: Plug in your compressor to an electrical outlet (See Figure H).

Figure H

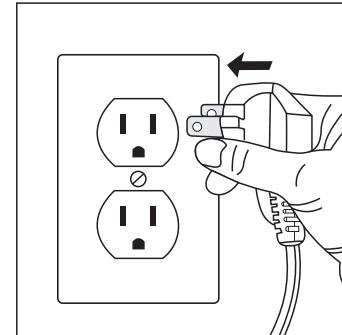

Step 11: Open the tobramycin inhalation solution ampule by holding the bottom tab with 1 hand and twisting off the top of the tobramycin inhalation solution ampule with the other hand (See Figure I). Be careful not to squeeze the tobramycin inhalation solution ampule until you are ready to empty all the medicine into the Nebulizer Cup.

Figure I

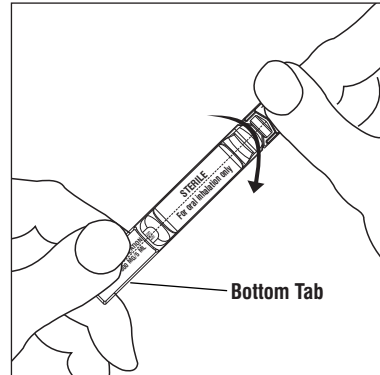

Step 12: Squeeze all the medicine of the tobramycin inhalation solution ampule into the Nebulizer Cup (See Figure J).

Figure J

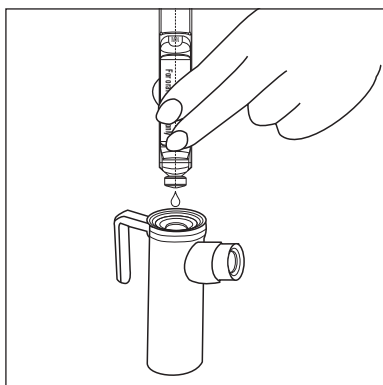

Step 13: Replace the Nebulizer Top. To replace the Nebulizer Top insert the Nebulizer Top into the Nebulizer Cup with the semi-circle halfway down the stem of the Nebulizer Top facing the Nebulizer Outlet. Turn the Nebulizer Top clockwise until securely fastened to the nebulizer Cup. (See Figure K).

Figure K

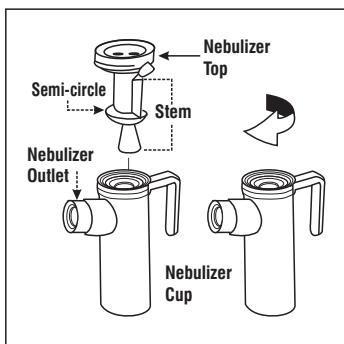

Step 14: Push the Mouthpiece straight onto the Nebulizer Outlet (See Figure L).

Figure L

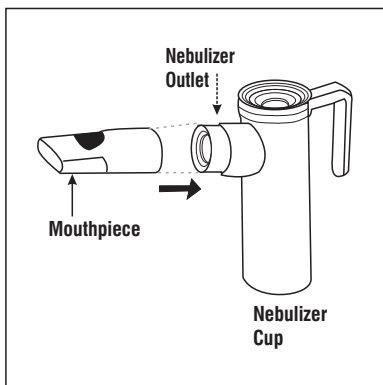

Step 15: Firmly push the Inspiratory Valve Cap straight down onto the Nebulizer Top (See Figure M). The Inspiratory Valve Cap will fit tightly.

Figure M

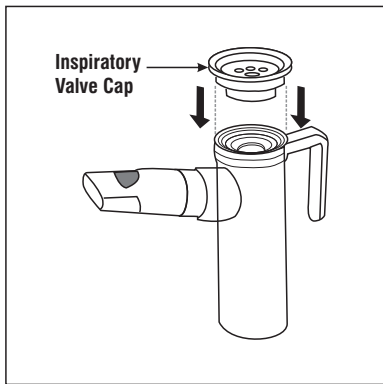

Step 16: Hold the Nebulizer Cup upright and firmly push the free end of the tubing from the compressor to the Air Intake on the bottom of the Nebulizer Cup (See Figure N). **Make sure to keep the Nebulizer Cup upright.**

Figure N

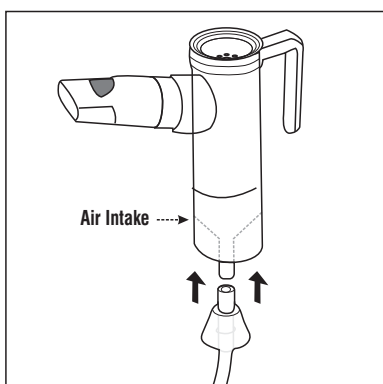

Giving your Tobramycin Inhalation Solution Inhalation Therapy

Step 17: Turn on the compressor (See Figure O).

Figure O

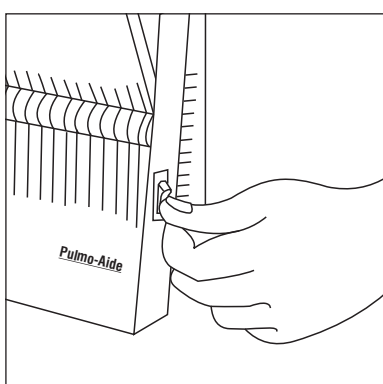

Step 18: Check for a steady mist from the Mouthpiece (See Figure P). If there is no mist, check all tubing connections and make sure that the compressor is working properly.

Figure P

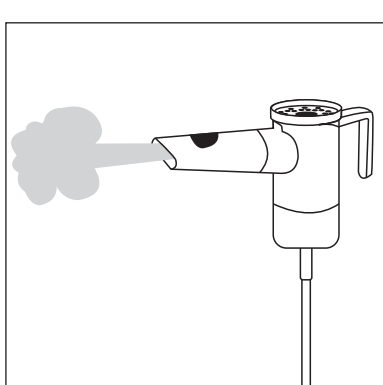

Step 19: Sit or stand in an upright position that will allow you to breathe normally. Place the Mouthpiece between your teeth and on top of your tongue and breathe normally only through your mouth (See Figure Q). Nose clips may help you breathe through your mouth and not through your nose. **Do not** block the airflow with your tongue.

Figure Q

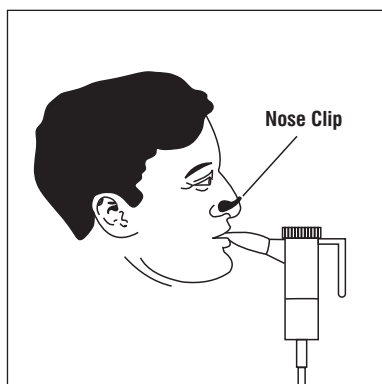

Step 20: Keep breathing in your tobramycin inhalation solution medicine for at least 15 minutes to get your full dose. Continue therapy until all your tobramycin inhalation solution medicine is gone, and there is no longer any mist being made. You may hear a sputtering sound coming from the Mouthpiece when the Nebulizer Cup is empty. The entire tobramycin inhalation solution therapy should take about 15 minutes to complete.

If you are interrupted, need to cough or rest during your tobramycin inhalation solution treatment, turn off the compressor to save your medicine. Turn the compressor back on when you are ready to restart your treatment.

Follow the nebulizer cleaning and disinfecting instructions after completing your therapy.

After your Tobramycin Inhalation Solution Inhalation Therapy Cleaning Your Nebulizer

To reduce the risk of infection, illness or injury from contamination, you must thoroughly clean all parts of the nebulizer as instructed after each treatment. Never use a nebulizer with a clogged nozzle. If the nozzle is clogged, no aerosol mist is made, and your therapy will not be as effective. Replace the nebulizer if clogging occurs.

- 1) Remove tubing from nebulizer and disassemble nebulizer parts.
- 2) Wash all parts (except tubing) with warm water and liquid dish soap.
- 3) Rinse thoroughly with warm water and shake out water.
- 4) Air dry or hand dry nebulizer parts on a clean, lint-free cloth. Reassemble nebulizer when dry, and store.

You can also wash all parts of the nebulizer in a dishwasher (except tubing).

- 1) Place the nebulizer parts in a dishwasher basket.
- 2) Place the dishwasher basket on the top rack of the dishwasher.
- 3) Remove and dry the parts when the cycle is complete.

Disinfecting Your Nebulizer

Your nebulizer is for your use only. **Do not** share your nebulizer with other people. You must disinfect the nebulizer every other treatment day. Failure to disinfect the nebulizer every other treatment day could lead to serious or fatal illness.

Clean the nebulizer as described above. Every other treatment day, disinfect the nebulizer parts (except tubing) by boiling them in water for a full 10 minutes. Dry parts on a clean, lint-free cloth.

Care and Use of Your Pulmo-Aide* Compressor

Follow the manufacturer instructions for care and use of your compressor.

Filter Change:

- DeVilbiss* Compressor filters should be changed every 6 months or sooner if the filter turns completely gray in color.

Compressor Cleaning:

- With power switch in the "Off" position, unplug power cord from wall outlet.
- Wipe outside of the compressor cabinet with a clean, damp cloth every few days to keep dust free.

Caution: **Do not** submerge in water because this will damage the compressor.

How should I store tobramycin inhalation solution?

- Store tobramycin inhalation solution ampules in a refrigerator between 36°F to 46°F (2°C to 8°C) until needed.
- You may store the tobramycin inhalation solution ampules in the foil pouches (opened or unopened) at room temperature 77°F (25°C) for up to 28 days.
- **Do not** use tobramycin inhalation solution ampules if they have been stored at room temperature for more than 28 days.
- Protect tobramycin inhalation solution ampules from light.

Keep tobramycin inhalation solution and all medicines out of the reach of children.

This Instructions for Use has been approved by the U.S. Food and Drug Administration.

Additional Information

Nebulizer: 1-800-327-8632
Compressor: 1-800-338-1988
Tobramycin Inhalation Solution: 1-800-818-4555

* All trademark names are the property of their respective owners.

Distributed by:
Sun Pharmaceutical Industries, Inc.
Cranbury, NJ 08512

Manufactured by:
Sun Pharmaceutical Medicare Limited
Baska Ujeti Road, Ujeti
Halol-389350, Gujarat, India

5239854
Rev. 04/2023